

THE INFORMATION CONTAINED HEREON IS PROPRIETARY AND CONFIDENTIAL TO DYNACOM CORPORATION. AND SHALL NOT BE USED OR DISCLOSED, IN WHOLE OR IN PART WITHOUT FIRST OBTAINING THE WRITTEN PERMISSION OF DYNACOM CORPORATION. SPECIFICATIONS SUBJECT TO CHANGE WITHOUT NOTICE.

ZONE	REV.	DESCRIPTION	DATE	APPV.
-	A	INITIAL RELEASE	7/7/2023	E.A.
-	B			
-	C			
-	D			

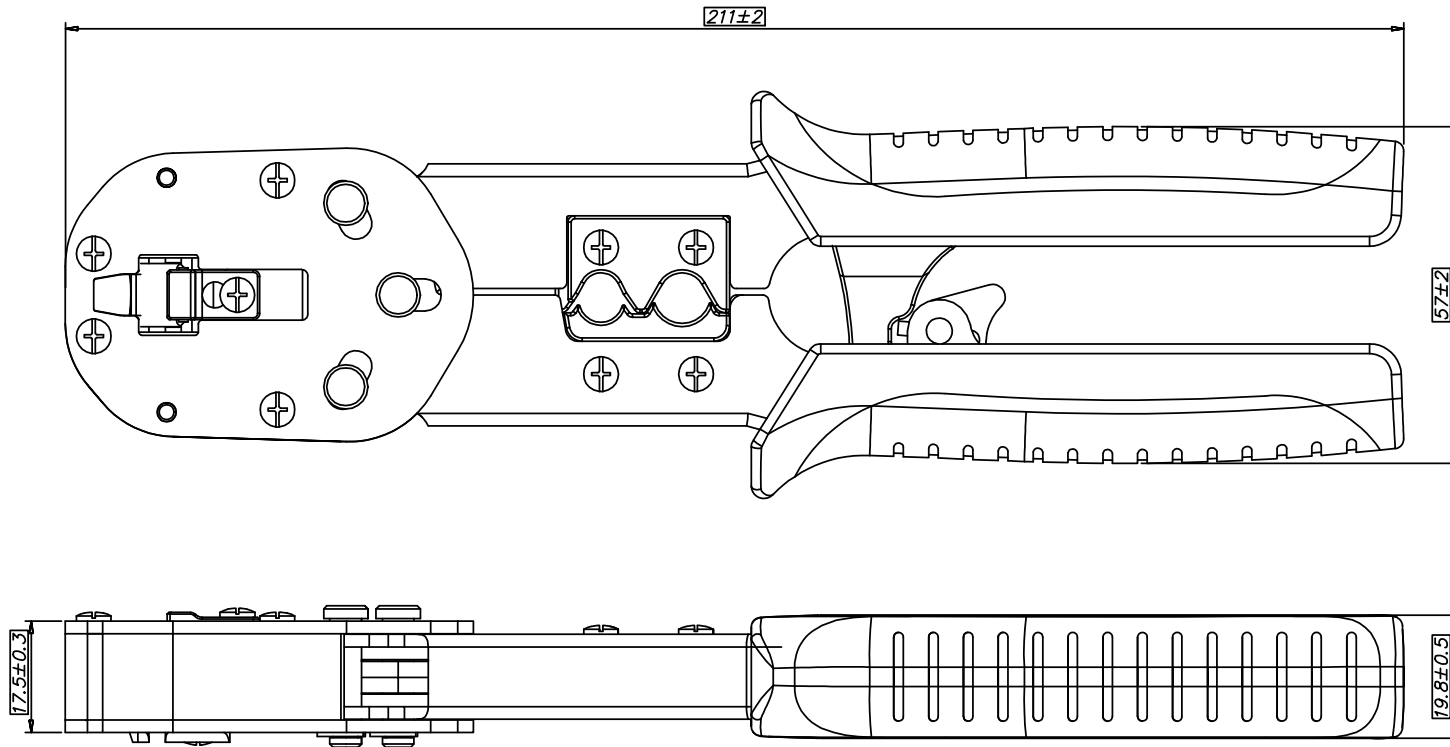

e-mail...sales@dynacomcorp.com
www.dynacomcorp.com

DIMENSIONS: MM

NEXT ASSY: -

DRAWN: E.A.

CHECKED: A.L.

TITLE
CRIMPING TOOL F/RJ45 PASS THROUGH

DWG. NO. SHEET 1 OF 2
6815-CRT

REV.
A

6815-CRT

RJ45 Universal Crimping Tool



Suitable For Various Connectors:

- ✓ Classic RJ 45 connectors (400Pxx connectors)
- ✓ Pass Through RJ45 connectors (401Pxx connectors)
- ✓ Connector WITH strain relief
- ✓ Connector WITHOUT strain relief
- ✓ Crimp ground arm on SLIM cable
- ✓ Crimp ground arm on THICK cable

Versatile crimp/trim blade

Adjustable pushing plate

Crimp external ground arm

Squeeze and lock



Made in Taiwan

Before crimping:

1. Check if your RJ45 connector has an internal strain relief.

2. Adjust the pushing plate to the proper position

