

THE INFORMATION CONTAINED HEREON IS PROPRIETARY AND CONFIDENTIAL TO DYNACOM CORPORATION, AND SHALL NOT BE USED OR DISCLOSED, IN WHOLE OR IN PART, WITHOUT FIRST OBTAINING THE WRITTEN PERMISSION FROM DYNACOM CORPORATION.

ZONE	REV	DESCRIPTION	DATE	APPV.
-	A	RELEASED.	02-03-2011	E.A.
-	B	NOTE 4: LOAD RATING ADDED.	07-08-2014	E.A.

NOTES:

1. MATERIAL: 0.060 COLD ROLLED STEEL.
2. FINISH: ZINC PLATED, COLOR SILVER, SIMILAR TO 40A-32 AND 40A-64.
3. BREAK ALL SHARP EDGES AND CORNERS.
4. LOAD RATING: 30 LBS.

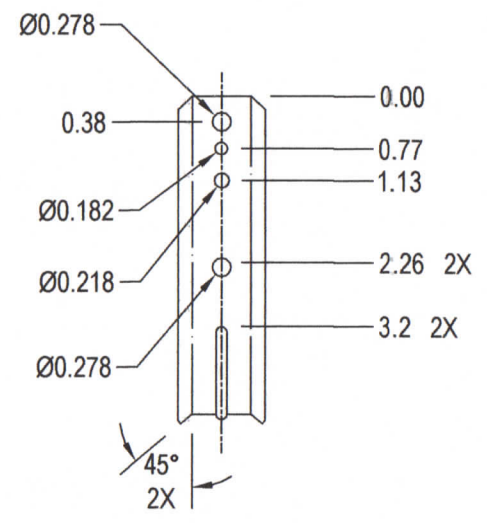
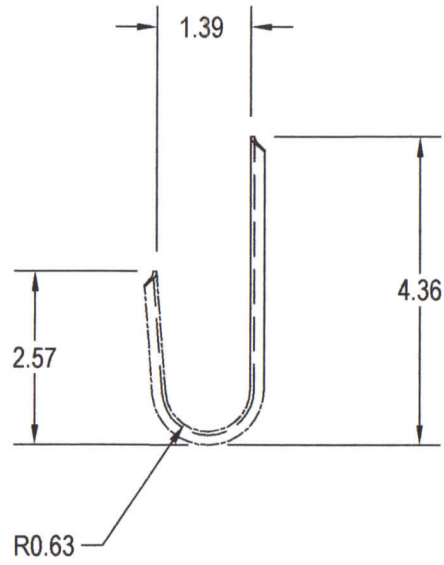
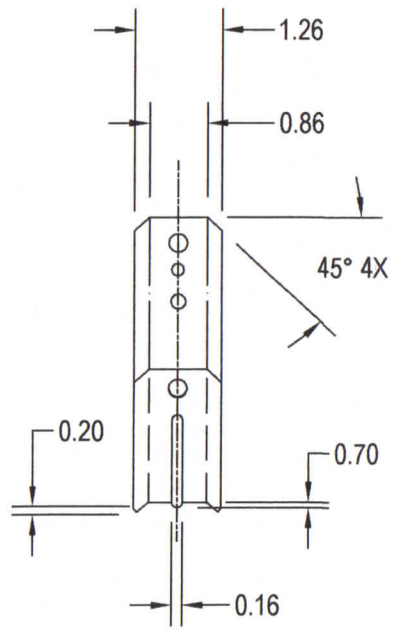

TOLS. .X=+/- 0.030, .XX=+/- 0.010, .XXX=+/- .005, ANGLES=+/- 5 DEG.



sales@dynacomcorp.com
www.dynacomcorp.com

NEXT ASSY-

DRAWN: E.A. 02-03-2011

CHECKED: E.A.

TITLE:

J-Hook, 1- 5/16 inch

DWG. NO. SHEET 1 OF 1

40A-21

REV.

B

THE INFORMATION CONTAINED HEREON IS PROPRIETARY AND CONFIDENTIAL TO DYNACOM CORPORATION, AND SHALL NOT BE USED OR DISCLOSED, IN WHOLE OR IN PART, WITHOUT FIRST OBTAINING THE WRITTEN PERMISSION FROM DYNACOM CORPORATION.

ZONE	REV	DESCRIPTION	DATE	APPV.
-	A	RELEASED.	02-03-2011	E.A.
-	B	NOTE 4: LOAD RATING ADDED.	07-08-2014	E.A.

NOTES:

1. MATERIAL: 0.060 COLD ROLLED STEEL.
2. FINISH: ZINC PLATED, COLOR SILVER, SIMILAR TO 40A-21 AND 40A-64.
3. BREAK ALL SHARP EDGES AND CORNERS.
4. LOAD RATING: 30 LBS.

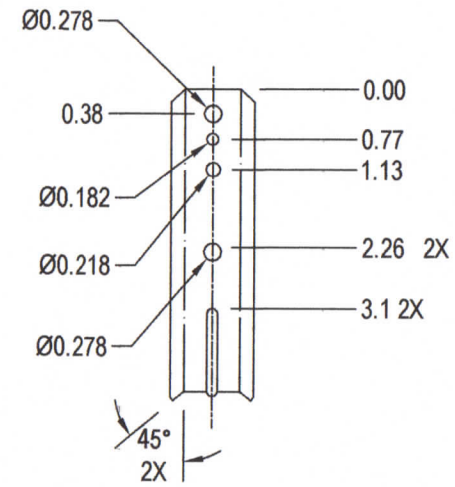
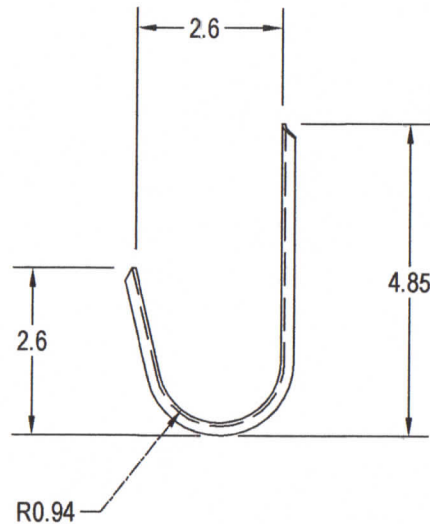
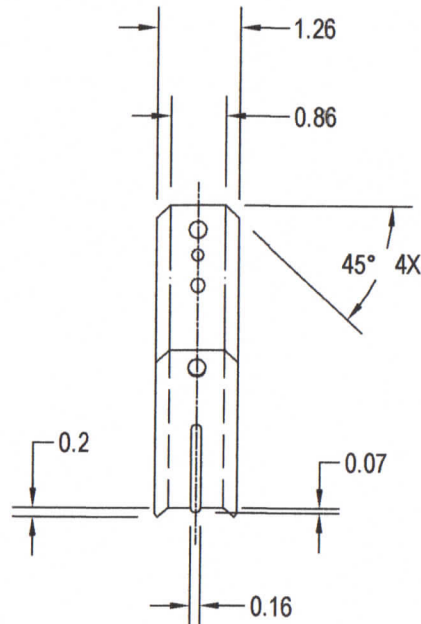

TOLS. .X=+/- 0.030, .XX=+/- 0.010, .XXX=+/- .005, ANGLES=+/- 5 DEG.



sales@dynacomcorp.com
www.dynacomcorp.com

NEXT ASSY-
TITLE:

DRAWN: E.A. 02-03-2011

CHECKED: E.A.

J-Hook, 2 inch

DWG. NO. SHEET 1 OF 1
40A-32

REV.
B

THE INFORMATION CONTAINED HEREON IS PROPRIETARY AND CONFIDENTIAL TO DYNACOM CORPORATION, AND SHALL NOT BE USED OR DISCLOSED, IN WHOLE OR IN PART, WITHOUT FIRST OBTAINING THE WRITTEN PERMISSION FROM DYNACOM CORPORATION.

ZONE	REV	DESCRIPTION	DATE	APPV.
-	A	RELEASED.	10/06/2008	E.A.
-	B	NOTE 3 ADDED. DWMG NO. CHANGED.	10/10/2008	E.A.
-	C	NOTE 4, LOAD RATING ADDED.	07/08/2014	E.A.

NOTES:

1. MATERIAL: 0.060 COLD ROLLED STEEL.
2. FINISH: ZINC PLATED, COLOR
3. BREAK ALL SHARP EDGES AND CORNERS.
4. LOAD RATING: 60 LBS.

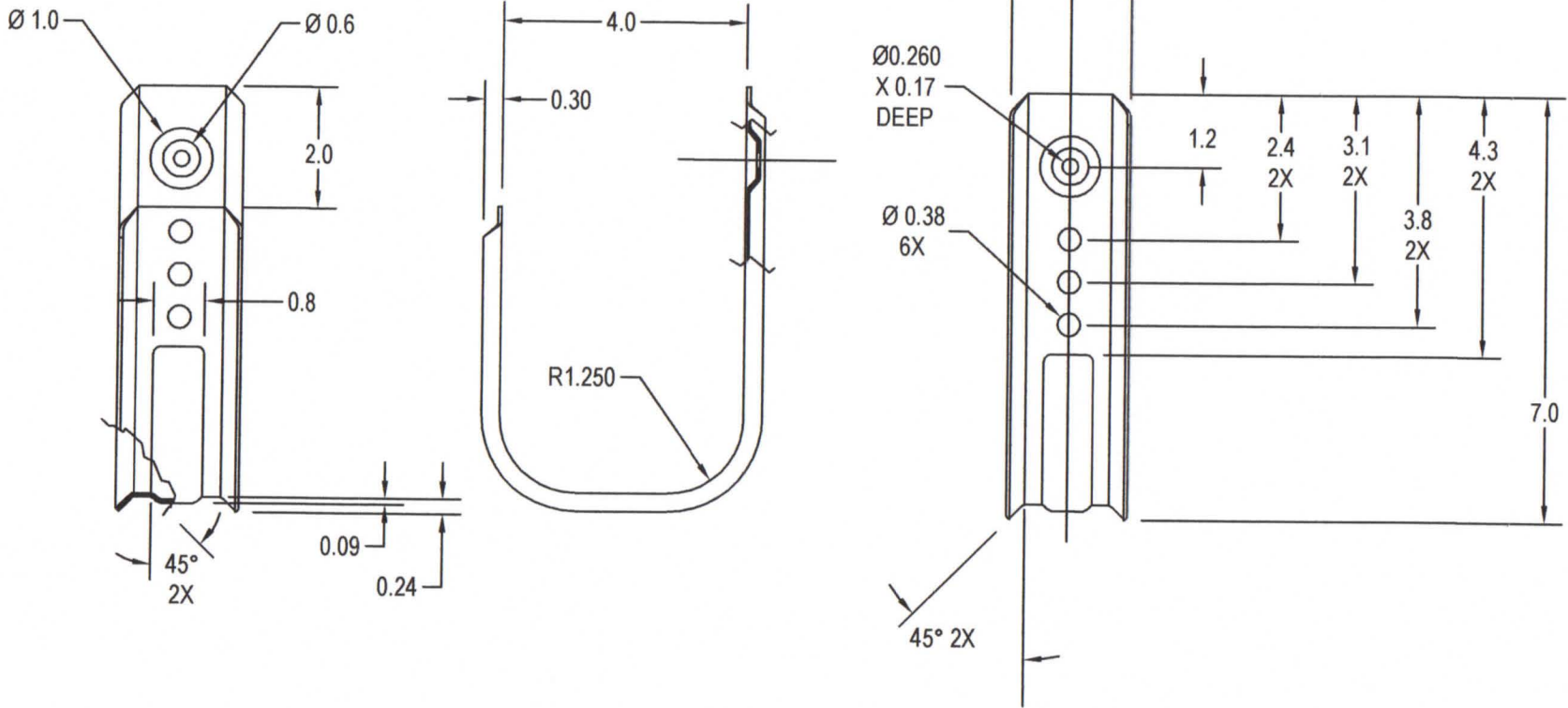

e-mail.....sales@dynacomcorp.com

web.....www.dynacomcorp.com

TOLS. .X=+/- 0.030, .XX=+/- 0.010, .XXX=+/- .005, ANGLES=+/- 5 DEG.

NEXT ASSY-

DRAWN: E.A.

CHECKED: E.A.

TITLE:

J-Hook, 4 inch

DWG. NO. SHEET 1 OF 1

40A-64

REV.

C