

1 2 3 4

THE INFORMATION CONTAINED HEREON IS PROPRIETARY AND CONFIDENTIAL TO DYNACOM CORPORATION. AND SHALL NOT BE USED OR DISCLOSED, IN WHOLE OR IN PART WITHOUT FIRST OBTAINING THE WRITTEN PERMISSION OF DYNACOM CORPORATION.

ZONE	REV.	DESCRIPTION	DATE	APPV.
-	A	INITIAL RELEASE	05/15/2014	E.A.

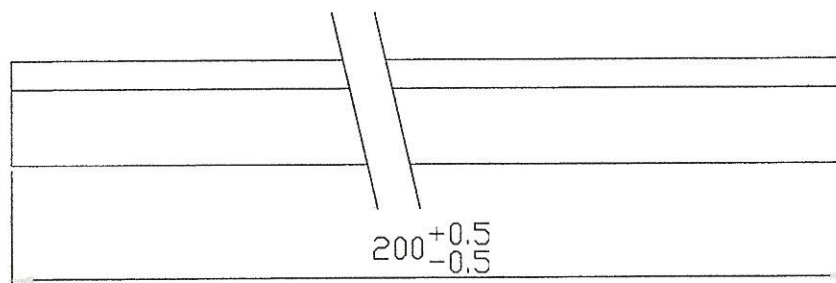
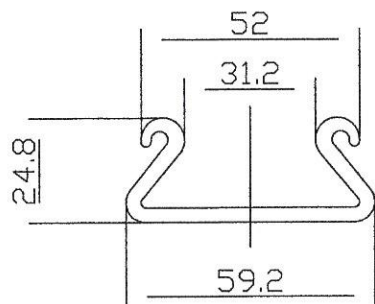

NOTE:

- 1.MAT'L-PVC
- 2.PART TO BE FREE OF SUCK SCRATCHES
- 3.GENERAL TOL: ± 0.2



e-mail...sales@dynacomcorp.com  
www.dynacomcorp.com

TOLS ~ 20MM ± 0.2MM, OVER 20MM TO 60MM ± 0.4MM, OVER 60MM ± 0.8MM. ANGLES ± 1 DEG			
NEXT ASSY: -	DRAWN: E.A. 05/15/2014	CHECKED: EA	
TITLE	DWG. NO.	SHEET 1 OF 1	REV.
HOLDER ID, PLASTIC, CLEAR	110PH		A