

THE INFORMATION CONTAINED HEREON IS PROPRIETARY AND CONFIDENTIAL TO DYNACOM CORPORATION. AND SHALL NOT BE USED OR DISCLOSED, IN WHOLE OR IN PART WITHOUT FIRST OBTAINING THE WRITTEN PERMISSION OF DYNACOM CORPORATION. SPECIFICATIONS SUBJECT TO CHANGE WITHOUT NOTICE.

ZONE	REV.	DESCRIPTION	DATE	APPV.
-	A	INITIAL RELEASE	5/1/2021	E.A.
-	B			
-	C			
-	D			

ISOMETRIC VIEW

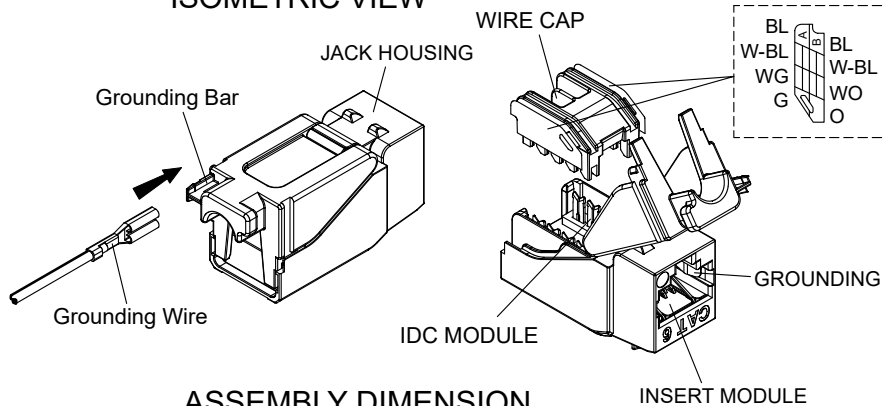

ASSEMBLY DIMENSION

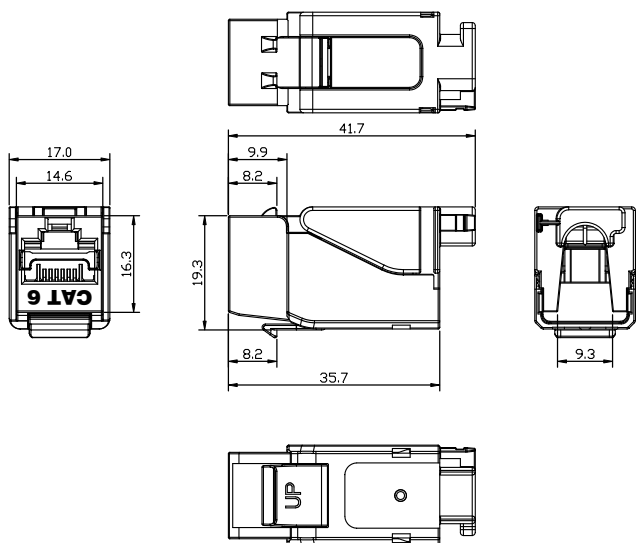

COMPONENTS

ITEM	PART NAME	Q'TY
6	WIRING LABEL	2
5	GROUNDING	1
4	IDC MODULE	1
3	WIRE CAP	1
2	INSERT MODULE	1
1	JACK HOUSING	1

TRANSMISSION PERFORMANCE
Meet all requirements specified in connecting hardware requirement of ANSI/TIA-568-C.2 Cat.6

ELECTRICAL
Electrical Insulation Resistance ≥ 500 M min. @ 100V d.c
Dielectric Withstanding Voltage : 1000V d.c. or a.c. Peak Contact to Contact @ 60Hz for 1 minute, 1500V d.c. or a.c. Peak; all contacts connected together to shield @ 60Hz for 1 minute.

MECHANICAL
Insertion / Extraction Life : 750 Cycles Minimum
IDC Wire Gauge : Re-usable IDC's can be terminated 20 times with wires from 24 AWG through 22 AWG.

PHYSICAL
Housing : Zinc-alloy fully shielded
Spring Wire : Phosphor Bronze Alloy Plated With 50 micro-inch of Gold
IDC : Phosphor Bronze Alloy With 100 micro-inch 100% Sn Alloy



e-mail...sales@dynacomcorp.com
www.dynacomcorp.com

DIMENSIONS: MM

NEXT ASSY: -

DRAWN: E.A.

CHECKED: A.L.

TITLE

CAT6 HD SHIELD JACK, TOOL-LESS

DWG. NO.

10606-FTP

SHEET 1 OF 1

REV.

A